

ATUS
澳托士液压

ATUS
澳托士液压
ATUS HYDRAULIC MACHINERY

深圳市澳托士液压机械有限公司
Shenzhen Aotuoshi Hydraulic Machinery Co., Ltd.

📍 地址：深圳市光明区公明街道上村社区莲塘工业区
☎ 电话：0755-23197339
✉ 邮箱：aotuoshi@atus.email
🌐 官网：<https://www.ats86.com>





深圳总厂
Shenzhen headquarters



惠州分厂
Huizhou Branch

公司简介 Company Profile

深圳市澳托士液压机械有限公司是一家集研发、制造、维修、销售液压泵、马达、阀为一体的综合性液压服务企业。产品和技术广泛应用于矿山机械、船舶机械、工程机械、农业机械、电厂设备、注塑机、压铸机、钢铁厂等各行业领域中，液压系统项目改造，国产化低成本替代进口改造、液压系统升级优化、节能提速改造。秉承“以人才引领创新，以创新引领发展”的用人观念，始终把人才队伍建设作为公司发展第一要务。设备配套方面公司拥有多套高精度数控加工设备，多条专业液压零件加工生产线，产品装配线以及完备的产品出厂检验装置，设备具有国内领先技术，实现了生产加工数控化，产品检验自动化。坚持“以科技为导向，以质量赢市场”的经验方针，把客户需求和客户满意作为公司发展的追求目标，以优质的产品和快捷的售后服务，致力于为社会创造价值，为客户创造效益。

Shenzhen Aotouoshi Hydraulic Machinery Co., Ltd. is a comprehensive hydraulic service enterprise that specializes in research and development, manufacturing, maintenance, and sales of hydraulic pumps, motors, and valves. Our products and technology find wide applications across various industries, including mining machinery, marine machinery, construction machinery, agricultural machinery, power plant equipment, injection molding machines, die-casting machines, and steel plants. We excel in hydraulic system project upgrades, cost-effective domestic substitutions for imports, hydraulic system enhancements, and energy-efficient speed improvements. Following the concept of "nurturing innovation through talent and leading development through innovation," we consistently prioritize the development of our talent pool as the foremost priority for our company. In terms of equipment and facilities, our company possesses multiple sets of high-precision CNC machining equipment, several specialized hydraulic component production lines, product assembly lines, and comprehensive product quality inspection facilities. Our equipment is at the forefront of domestic technology, enabling CNC production processing and automated product inspection. We adhere to the guiding principle of "technology as our compass, quality as our market advantage," with customer needs and satisfaction as the driving goals for our company's development. We are committed to creating value for society and benefits for our customers through high-quality products and efficient after-sales service.

目录 CONTENTS

公司简介	01	ATUS-F12 系列	26
目录	02	ATUS-KMF90 系列	27
应用领域	03	ATUS-A6V 系列	28
企业资格和荣誉证书	04	ATUS-PVP 系列	29
企业展示	05	ATUS-PVM 系列	30
仓库原材料	06	ATUS-A2F 系列	31
ATUS-A6VM 系列	07	ATUS-A2FO 系列	32
ATUS-AA6VM 系列	08	ATUS-A22VG 系列	33
ATUS-A6VE 系列	09	ATUS-A4VSO 系列	34
ATUS-M(定量) 系列	10	ATUS-LR/KR 系列	35
ATUS-M(变量) 系列	11	ATUS-ER 系列	36
ATUS-P 系列	12	ATUS-JR 系列	37
ATUS-A10V(S)O 32 系列	13	ATUS-FR 系列	38
ATUS-A10V(S)O 31 系列	14	ATUS-90 系列	39
ATUS-A10VNO 系列	15	ATUS-A7VO 系列	40
ATUS-A1VO 系列	16	ATUS-A2FM 系列	41
ATUS-PFB/PVB 系列	17	ATUS-A2FE 系列	42
ATUS-PD 系列	18	ATUS-A11V(L)O 系列	43
ATUS-PVH 系列	19	ATUS-A4VG 系列	44
ATUS-PVXS 系列	20	ATUS-P2/P3 系列	45
ATUS-D-PV 系列	21	ATUS-PAVC 系列	46
ATUS-PV 系列	22	ATUS-ADU 系列	47
ATUS-A10VG 系列	23	ATUS-9A 阀 系列	48
ATUS-A20VO 系列	24	ATUS-300 系列 减速机	49
ATUS-F11 系列	25	ATUS-ED 系列 减速机	50

应用领域：
Hydraulic pump application areas:



造纸
Papermaking



军工
Military



冶金
Smelting

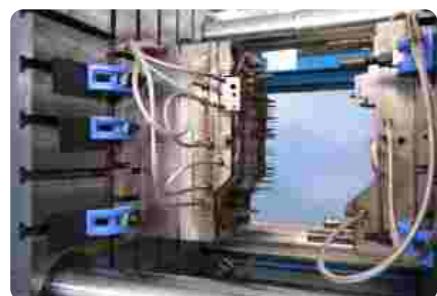

成型
Forming



桩工
Pile Work



建设
Construction



农业
Agriculture



海洋开采
Ocean mining



煤矿
Mining



电力
Electricity



船舶
Ships



码头
Pier

企业资质和荣誉证书：
Enterprise qualifications and honors:

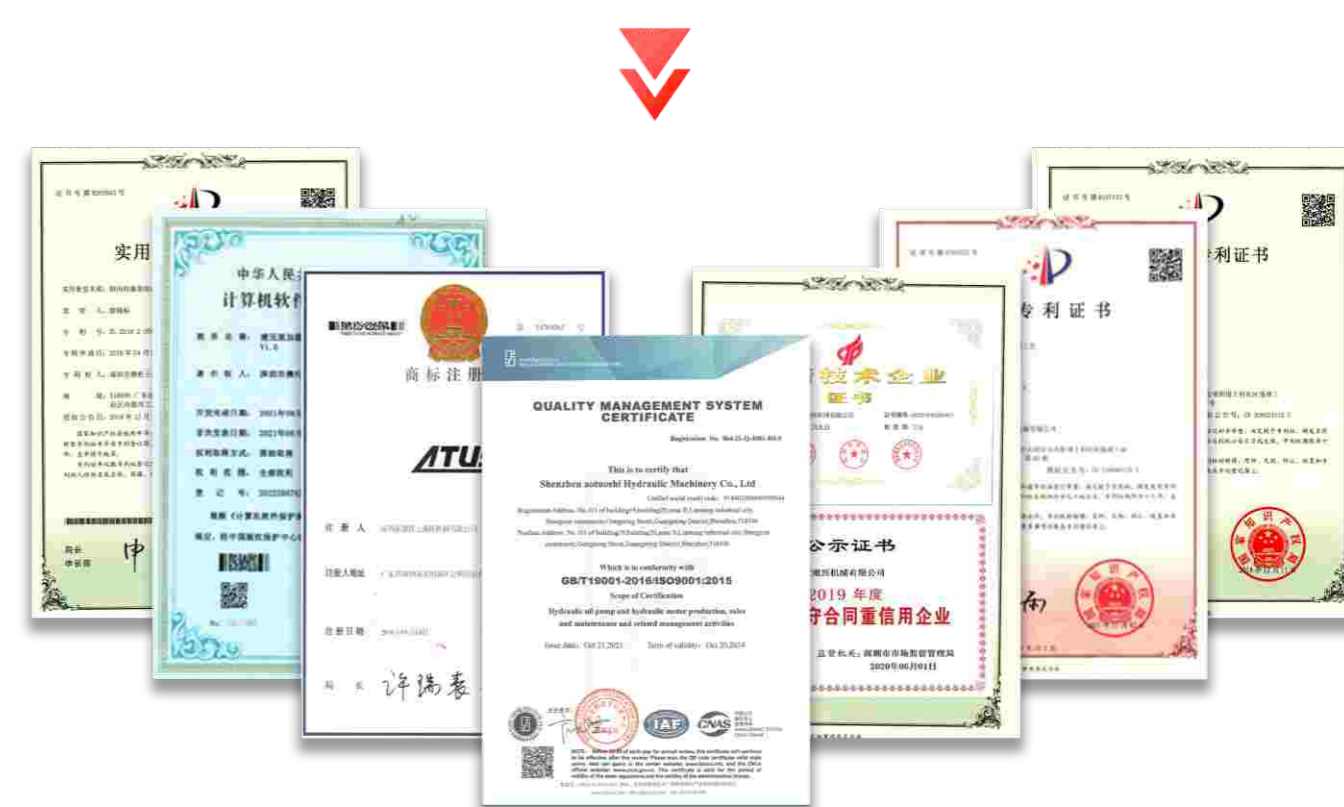

企业展示： Enterprise Show:



仓库原材料： Raw materials display in warehouse:





ATUS-A6VM 系列

轴向柱塞变量马达
Axial Piston Variable Motor

产品参数及特点 Product Parameters

规格 Size NG	28	55	80	107	140	160	200	250	355	500	1000
排量 Displacement (cm ³ /rev)	28	55	80	107	140	160	200	250	355	500	1000
转速 Speed (rpm)	5550	4450	3900	3550	3250	3100	2900	2700	2240	2000	1600
公称压力 Nominal pressure (bar)	400						350				
峰值压力 Max. pressure (bar)	450						400				
扭矩 Torque p=350bar (Nm)	157	305	446	596	778	891	1114	1391	1978	2785	5571
重量(近似值) Weight(approx.) (kg)	16	26	34	47	60	64	80	100	170	210	430
应用领域 Application field	应用于高速旋转驱动，如：旋挖钻机动力头，行走驱动，卷扬驱动等工程机械 Used in high-speed rotating drives, such as: rotary drilling rig power heads, traveling drives, winch drives and other engineering machinery										



扫一扫查看电子说明书
Electronic instruction manual



ATUS-AA6VM 系列

轴向柱塞变量马达
Axial Piston Variable Motor

产品参数及特点 Product Parameters

规格 Size NG	28	55	80	107	140	160	200	250	355	500	1000
排量 Displacement (cm ³ /rev)	28.1	54.8	80	107	140	160	200	250	355	500	1000
转速 Speed (rpm)	5550	4450	3900	3550	3250	3100	2900	2700	2240	2000	1600
公称压力 Nominal pressure (bar)	400						350				
峰值压力 Max. pressure (bar)	450						400				
扭矩 Torque p=350bar (Nm)	179	349	509	681	891	1091	1273	1391	1978	2785	5571
重量(近似值) Weight(approx.) (kg)	16	26	34	47	60	64	80	100	170	210	430
应用领域 Application field	应用于工程机械、农业机械、林业机械、矿山设备等，液压行走，及需要高速旋转的工作部位。 Used in engineering machinery, agricultural machinery, forestry machinery, mining equipment, etc., hydraulic travel, and working parts that require high-speed rotation.										



扫一扫查看电子说明书
Electronic instruction manual

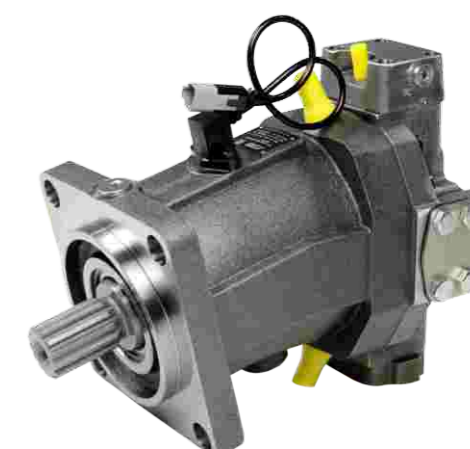



ATUS-A6VE 系列

插入式柱塞变量马达
Plug-in Plunger Variable Motor

产品参数及特点 Product Parameters

规格 Size NG	28	55	80	107	160	250
排量 Displacement (cm ³ /rev)	28	55	80	107	160	250
转速 Speed (rpm)	5550	4450	3900	3550	3100	2700
公称压力 Nominal pressure (bar)	400					350
峰值压力 Max. pressure (bar)	450					400
扭矩 Torque p=350bar (Nm)	157	305	446	596	891	1391
重量(近似值) Weight(approx.) (kg)	16	26	34	47	64	90
应用领域 Application field	应用于矿机、船舶机械、工程机械、发电厂设备、注塑机、钢厂等 Used in mining machinery, ship machinery, engineering machinery, power plant equipment, injection molding machines, steel plants, etc.					

ATUS-M 系列

轴向柱塞定量马达
Axial Piston Metering Motor

产品参数及特点 Product Parameters

规格 Size NG	6	7	11	14	24	30
排量 Displacement (ml/rev)	98.3	118.8	180.3	229.5	403.2	501.5
转速 Speed (rpm)	3000	3000	2400	2400	2100	1800
扭矩 Torque p=350bar (Nm)	539.5	651.9	990	1250	2158	2752
公称压力 Nominal pressure (bar)	350					
峰值压力 Max. pressure (bar)	420					
重量(近似值) Mass (approx.) (kg)	50	50	110	110	230	270
应用领域 Application field	应用于工程机械、油田特种车、矿山设备等需要大扭矩特种行走机械中。 Used in engineering machinery, specialized vehicles for oilfields, mining equipment, and other specialized mobile machinery requiring high torque.					



扫一扫查看电子说明书
Electronic instruction manual

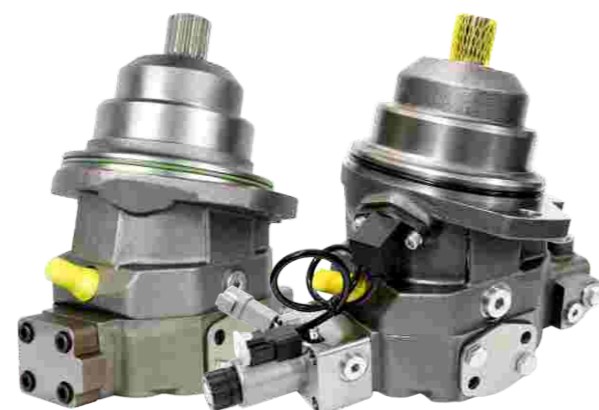

扫一扫查看电子说明书
Electronic instruction manual





ATUS-M 系列

轴向柱塞变量马达

Axial Piston Variable Motor

产品参数及特点

Product Parameters

规格 Size NG	6	7	11	14	24	30
排量 Displacement (ml/rev)	98.3	118.8	180.3	229.5	403.2	501.5
转速 Speed (rpm)	3000	3000	2400	2400	2100	1800
扭矩 Torque p=350bar (Nm)	539.5	651.9	990	1250	2158	2752
公称压力 Nominal pressure (bar)	350					
峰值压力 Max. pressure (bar)	420					
重量(近似值) Mass (approx.) (kg)	50	50	135	135	290	300
应用领域 Application field	应用于钻机旋动力头, 船舶起重机, 回转装置等需要大扭矩旋转的工作部位 Used in drilling rig rotating power heads, ship cranes, slewing devices and other working parts that require large torque rotation					



扫一扫查看电子说明书
Electronic instruction manual



ATUS-P 系列

轴向柱塞变量泵

Axial Piston Variable Pump

产品参数及特点

Product Parameters

规格 Size NG	6	7	8	11	14	24	30
排量 Displacement (cm ³ /rev)	98.3	118.8	131.1	180.3	229.5	403.2	501.5
转速 Speed (rpm)	3000	3000	2100	2400	2400	2100	1800
流量 Flow (L/min)	294.9	356.4	275.31	432.72	550.8	846.72	902.7
公称压力 Nominal pressure (bar)	350						
峰值压力 Maximum pressure (bar)	420						
重量(近似值) Weight (approx.) (kg)	80-135	80-135	80-135	145-240	145-240	340-375	340-375
应用领域 Application field	用于大型液压站, 如发电厂、造纸厂、造船厂等 Used in large hydraulic stations, such as power plants, paper mills, shipyards, etc.						



扫一扫查看电子说明书
Electronic instruction manual

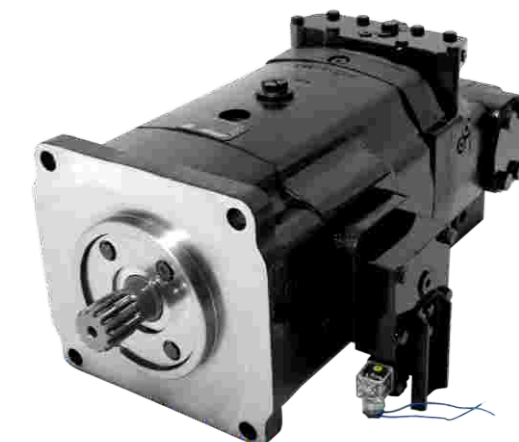

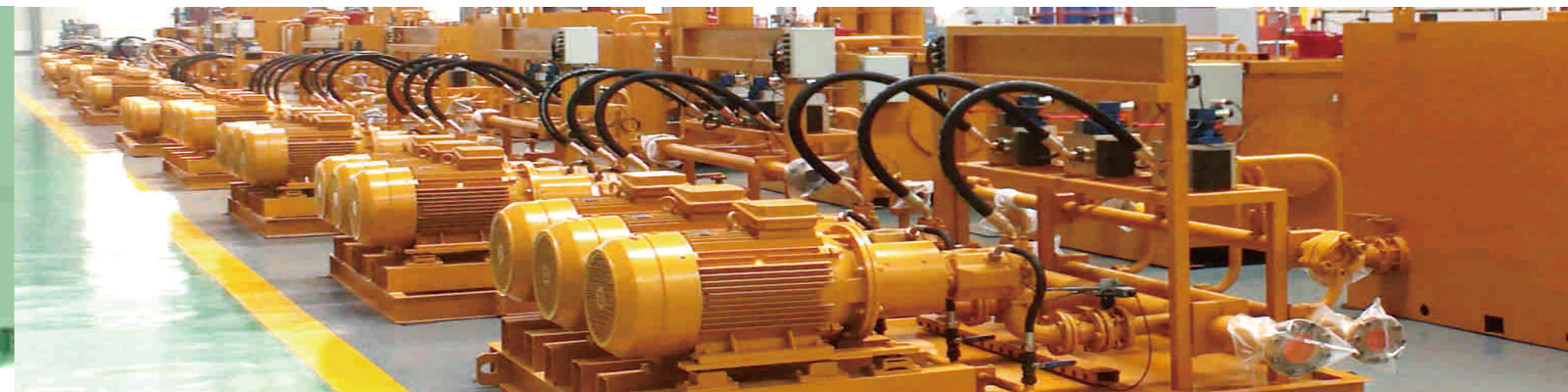

ATUS-A10V(S)O 32系列

轴向柱塞变量泵
Axial Piston Variable Pump

产品参数及特点 Product Parameters

规格 Size NG	45	71	100	140	180
排量 Displacement (cm ³ /rev)	45	71	100	140	180
转速 Speed (rpm)	3000	2550	2300	2200	1800
流量 Flow (L/min)	135	181	280	308	324
公称压力 Nominal pressure (bar)	280				
峰值压力 Max. pressure (bar)	350				
重量(近似值) Weight(approx.) (kg)	30	47	69	73	78

应用领域 Application field

应用于工业开式回路液压系统中，涉及行业：注塑，冶炼，化工，采矿...
Used in industrial open circuit hydraulic systems, involving industries: injection molding, smelting, chemical industry, mining...



扫一扫查看电子说明书
Electronic instruction manual



ATUS-A10V(S)O 31系列

轴向柱塞变量泵
Axial Piston Variable Pump

产品参数及特点 Product Parameters

规格 Size NG	18	28	45	71	100	140
排量 Displacement (cm ³ /rev)	18	28	45	71	100	140
转速 Speed (rpm)	3300	3000	2600	2200	2000	1800
流量 Flow (L/min)	59	84	117	156	200	252
公称压力 Nominal pressure (bar)	280					
峰值压力 Max. pressure (bar)	350					
重量(近似值) Weight(approx.) (kg)	12	15	21	33	45	60

应用领域 Application field

应用于工程机械，压铸机，注塑机，化工设备等液压系统中
Used in hydraulic systems such as engineering machinery, die-casting machines, injection molding machines, chemical equipment, etc.



扫一扫查看电子说明书
Electronic instruction manual





ATUS-A10VNO 系列

轴向柱塞变量泵
Axial Piston Variable Pump

产品参数及特点 Product Parameters

规格 Size NG	28	41	63	85
排量 Displacement (cm ³ /rev)	28	41	63	85
转速 Speed (rpm)	3200	2900	2700	2700
流量 Flow (L/min)	90	119	170	230
公称压力 Nominal pressure (bar)	210			
峰值压力 Max. pressure (bar)	250			
重量(近似值) Weight (approx.) (kg)	11.5	14	18	22
应用领域 Application field	应用于农业、工业、林业等领域 Used in agriculture, industry, forestry and other fields			

ATUS-A1V0 系列

轴向柱塞变量泵
Axial Piston Variable Pump

产品参数及特点 Product Parameters

规格 Size NG	35
排量 Displacement (cm ³ /rev)	35
转速 Speed (rpm)	3000
流量 Flow (L/min)	105
公称压力 Nominal pressure (bar)	250
峰值压力 Max. pressure (bar)	280
重量(近似值) Weight (approx.) (kg)	16.9
应用领域 Application field	应用于农业，小型拖拉机的液压系统 Hydraulic systems used in agriculture and small tractors



扫一扫查看电子说明书
Electronic instruction manual



扫一扫查看电子说明书
Electronic instruction manual





ATUS-PFB/PVB 系列

定量和变量轴向柱塞泵
Fixed And Variable Displacement Axial Piston Pumps

产品参数及特点 Product Parameters

规格 Size NG	5	6	10	15	20	29	45	90
排量 Displacement (cm ³ /rev)	10.5	13.8	21.1	33.0	42.8	61.6	94.5	197.5
转速 Speed (rpm)	1800	1800	1800	1800	1800	1800	1800	1800
流量 Flow (L/min)	18.9	24.84	37.98	59.4	77.04	110.88	170.1	355.5
公称压力 Nominal pressure (bar)	210	140	210	140	210	140	210	210
峰值压力 Max. pressure (bar)	280	200	280	200	280	200	280	280
重量(近似值) Weight(approx.) (kg)	8	8	15	15	26	26	96	104
应用领域 Application field	应用于工程机械、油田、船舶等机械领域 Used in engineering machinery, oil fields, ships and other machinery fields							

ATUS-PD 系列

中载轴向柱塞式变量泵
Medium Pressure Axial Piston Pumps

产品参数及特点 Product Parameters

规格 Size NG	18	28	45	60	75	100	140
排量 Displacement (cm ³ /rev)	18	28	45	60	75	100	140
转速 Speed (rpm)	1800						
流量 Flow (L/min)	32.4	50.4	81	108	135	180	252
公称压力 Nominal pressure (bar)	280						
峰值压力 Max. pressure (bar)	320						
重量(近似值) Weight(approx.) (kg)	14.2	18.1	24	30	31	53	67
应用领域 Application field	应用于工业设备和工程设备的液压系统 Hydraulic systems used in industrial equipment and engineering equipment						



扫一扫查看电子说明书
Electronic instruction manual

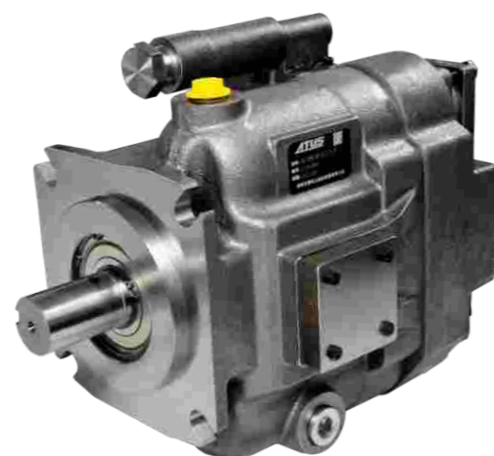

扫一扫查看电子说明书
Electronic instruction manual



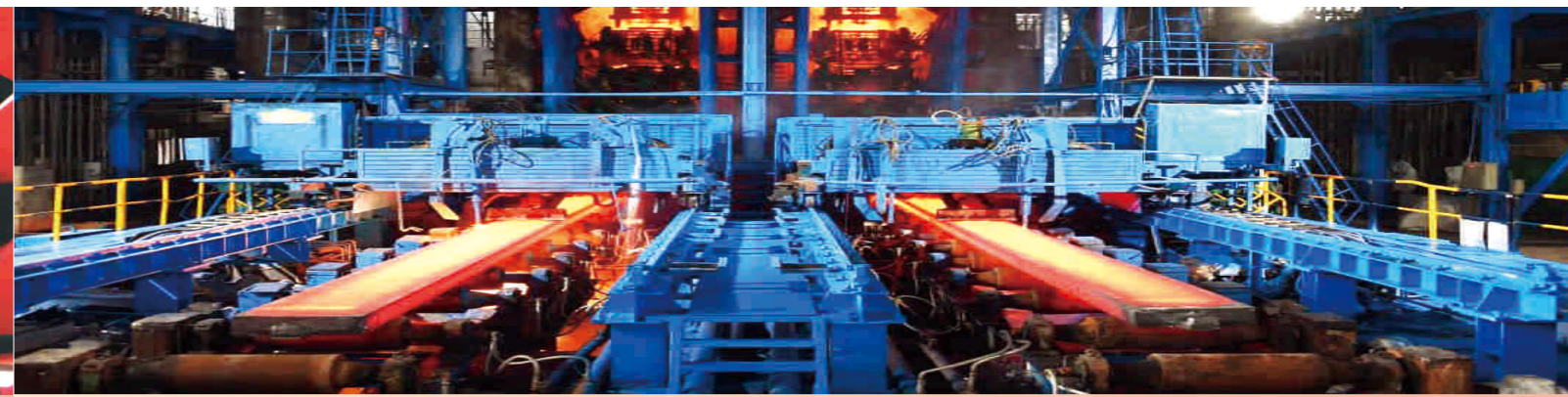

ATUS-PVH 系列

轴向柱塞变量泵

Axial Piston Variable Pump

产品参数及特点 Product Parameters

规格 Size NG	57	74	98	131
排量 Displacement (cm ³ /rev)	57.4	73.7	98.3	131.1
转速 Speed (rpm)	1800			
流量 Flow (L/min)	98	125	170	223
公称压力 Nominal pressure (bar)	250			
峰值压力 Max. pressure (bar)	300			
重量(近似值) Weight (approx.) (kg)	31	42	44	62
应用领域 Application field	应用于钢厂、轧钢机、加热炉以及土方机械、建筑机械、机床、塑料机械等 Used in steel plants, rolling mills, heating furnaces, earthmoving machinery, construction machinery, machine tools, plastic machinery, etc.			

ATUS-PVXS 系列

轴向柱塞变量泵

Axial Piston Variable Pump

产品参数及特点 Product Parameters

规格 Size NG	66	90	130	180	250
排量 Displacement (cm ³ /rev)	66	90	130	180	250
转速 Speed (rpm)	1800				
流量 Flow (L/min)	118	162	234	324	450
公称压力 Nominal pressure (bar)	350				
峰值压力 Max. pressure (bar)	420				
重量(近似值) Weight (approx.) (kg)	55	75	106	114	212
应用领域 Application field	应用于工业领域、钢铁厂、发电厂、注塑机等 Used in industrial fields, steel plants, power plants, injection molding machines, etc.				



扫一扫查看电子说明书
Electronic instruction manual



扫一扫查看电子说明书
Electronic instruction manual

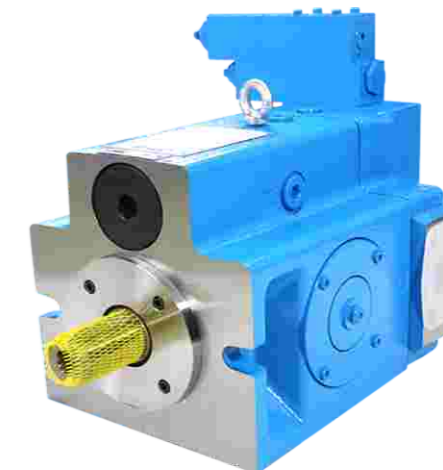



ATUS-D-PV 系列

轴向柱塞变量泵
Axial Piston Variable Pump

产品参数及特点 Product Parameters

规格 Size NG	6	10	15	20	29	38	47	64
排量 Displacement (cm ³ /rev)	14.4	20.6	34.2	42.9	61.9	80	100	130
转速 Speed (rpm)	3000	3000	2500	2400	2400	1800	1800	1800
流量 Flow (L/min)	43.2	61.8	85.5	102.96	148.56	144	180	234
公称压力 Nominal pressure (bar)	240	240	240	240	207	280	280	280
峰值压力 Max. pressure (bar)	310	310	310	310	280	300	300	300
重量(近似值) Weight (approx.) (kg)	14	20	25	32	42	50	71	95

应用领域 Application field

应用于冶金工业、注塑机、矿山设备、工程机械等
Used in metallurgical industry, injection molding machines, mining equipment, engineering machinery, etc.



扫一扫查看电子说明书
Electronic instruction manual

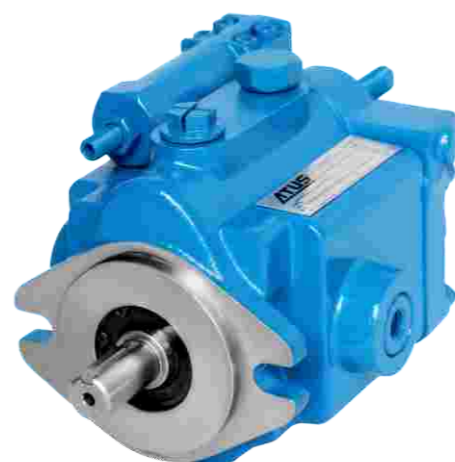

ATUS-PV 系列

轴向柱塞变量泵
Axial Piston Variable Pump

产品参数及特点 Product Parameters

规格 Size NG	16	20	23	28	32	40	46	63	80	92	140	180	270	360
排量 Displacement (cm ³ /rev)	16	20	23	28	32	40	46	63	80	92	140	180	270	360
转速 Speed (rpm)	3000	3000	3000	3000	2800	2800	2800	2800	2500	2300	2400	2200	1800	1750
流量 Flow (L/min)	48	60	69	84	90	112	129	176	200	212	336	396	486	630
公称压力 Nominal pressure (bar)	350													
峰值压力 Max. pressure (bar)	420													
重量(近似值) Weight (approx.) (kg)	19	19	19	19	30	30	30	59	59	59	90	90	172	180

应用领域 Application field

用于开放式液压系统，主要用于钢铁行业、造纸行业、工程机械等
Used in open hydraulic systems, mainly used in the steel industry, paper industry, construction machinery, etc.



扫一扫查看电子说明书
Electronic instruction manual





ATUS-A10VG 系列

轴向柱塞变量泵
Axial Piston Variable Pump

产品参数及特点 Product Parameters

规格 Size NG	18	28	45	63
排量 Displacement (cm ³ /rev)	18	28	45	63
转速 Speed (rpm)	4000	3900	3300	3000
流量 Flow (L/min)	72	109	152	189
公称压力 Nominal pressure (bar)	300			
峰值压力 Max. pressure (bar)	350			
重量(近似值) Weight (approx.) (kg)	14	25	27	39
应用领域 Application field	应用于闭式系统，主要用于农机和工程机械中 Used in closed systems, mainly used in agricultural machinery and construction machinery			

ATUS-A20VO 系列

轴向柱塞变量双泵
Axial Piston Variable Double Pump

产品参数及特点 Product Parameters

规格 Size NG	60	95	190	260	520
排量 Displacement (cm ³ /rev)	60	93.8	192.7	260	520
转速 Speed (rpm)	2700	2350	2500	2300	1450
流量 Flow (L/min)	2x162	2x220	2x482	2x598	2x754
公称压力 Nominal pressure (bar)	250	350			
峰值压力 Max. pressure (bar)	315	400			
应用领域 Application field	应用于农业机械、船舶、矿山机械等液压系统中 Used in hydraulic systems such as agricultural machinery, ships, and mining machinery				



扫一扫查看电子说明书
Electronic instruction manual



扫一扫查看电子说明书
Electronic instruction manual

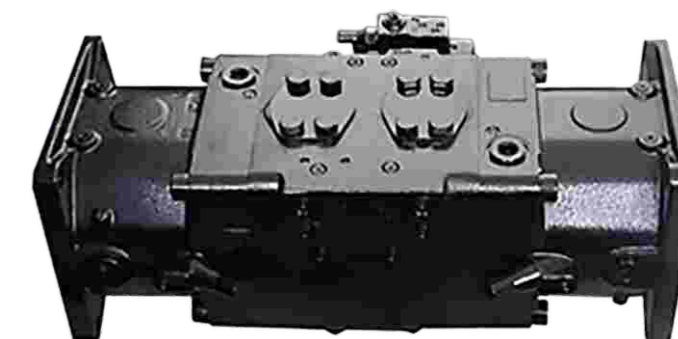



ATUS-F12 系列 斜轴定量马达 Inclined Axis Quantitative Motor

产品参数及特点 Product Parameters

规格 Size NG	30	40	60	80	90	110	125	152	162	182	250
排量 Displacement (cm ³ /rev)	30.0	40.0	59.8	80.4	93.0	110.1	125.0	149.8	163.1	179.8	242.0
转速 Speed (rpm)	6700	6100	5300	4800	4600	4400	4200	3700	3700	3700	2700
公称压力 Nominal pressure (bar)	420										
峰值压力 Max. pressure (bar)	480										
扭矩 Torque p=350bar (Nm)	167	222	332	447	517	612	694	844	900	1012	1345
重量(近似值) Mass(approx.) (kg)	11.5	15.7	18.6	25.7	25.7	33	33	40	40	40	77
应用领域 Application field	应用于需要执高速旋转的机械设备中，如：液压行走，高速切削马达，旋挖动力头，卷扬机，高频振动桩锤等 Used in mechanical equipment that requires high-speed rotation, such as: hydraulic travel, high-speed cutting motors, rotary digging power heads, winches, high-frequency vibration pile hammers, etc.										

ATUS-F11 系列 斜轴定量马达 Inclined Axis Quantitative Motor

产品参数及特点 Product Parameters

规格 Size NG	5	6	10	12	14	19
排量 Displacement (cm ³ /rev)	4.9	6	9.8	12.5	14.3	19
转速 Speed (rpm)	12800	10200	10200	9400	9000	8100
公称压力 Nominal pressure (bar)	350					
峰值压力 Max. pressure (bar)	420					
扭矩 Torque p=350bar (Nm)	27.3	33.25	54.6	69.3	79.45	105.7
重量(近似值) Weight(approx.) (kg)	4.7	6.5	6.5	7.5	7.5	11
应用领域 Application field	应用于高速旋转马达，应用于阀木机、切削设备、行走等 Used in high-speed rotating motors, valve wood machines, cutting equipment, walking, etc.					



扫一扫查看电子说明书
Electronic instruction manual



扫一扫查看电子说明书
Electronic instruction manual





ATUS-KMF90 系列

插装式定量马达
Plug-in Quantitative Motor

产品参数及特点 Product Parameters

规格 Size NG	90
排量 Displacement (cm ³ /rev)	90
转速 Speed (rpm)	3000
公称压力 Nominal pressure (bar)	320
峰值压力 Max. pressure (bar)	350
扭矩 Torque p=320bar (Nm)	459
重量(近似值) Weight(approx.) (kg)	36

应用领域 Application field

应用于打桩机的高频振动马达，以及各类需要高速旋转的设备中
Used in high-frequency vibration motors of pile drivers and various types of equipment that require high-speed rotation



扫一扫查看电子说明书
Electronic instruction manual



ATUS-A6V 系列

变量柱塞马达
Variable Displacement Motor

产品参数及特点 Product Parameters

规格 Size NG	28	55	80	107	160	225	250	468
排量 Displacement (cm ³ /rev)	28.1	54.8	80	107	160	225	250	468
转速 Speed (rpm)	6250	5000	4500	4000	3500	3100	3100	2500
公称压力 Nominal pressure (bar)	350							
峰值压力 Max. pressure (bar)	400							
扭矩 Torque p=350bar (Nm)	156	305	445	595	890	1252	1391	2604
重量(近似值) Mass (approx.) (kg)	18	27	39	52	74	103	103	223

应用领域 Application field

应用于工程机械与矿山设备中，如：水平定向钻机，坑道全液压钻机，旋挖钻机等，需要高速旋转的工作部位。
Used in engineering machinery and mining equipment, such as horizontal directional drilling rigs, tunnel fully hydraulic drilling rigs, rotary drilling rigs, etc., which



扫一扫查看电子说明书
Electronic instruction manual



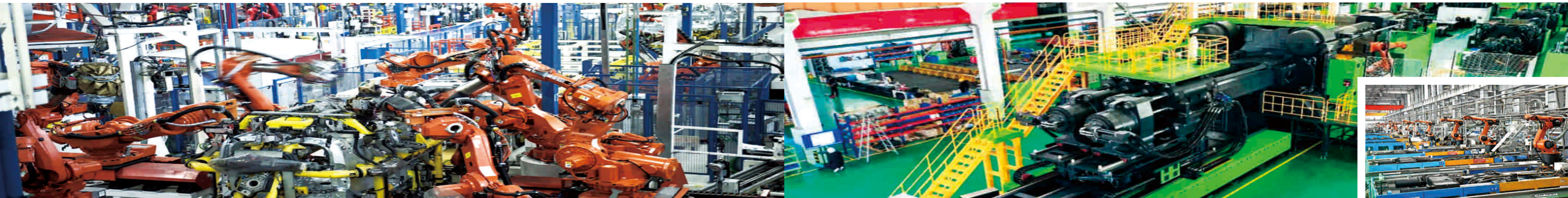

ATUS-PVP 系列

轴向柱塞变量泵

Axial Piston Variable Pump

产品参数及特点 Product Parameters

规格 Size NG	16	23	33	41	48	60	76	100	140
排量 Displacement (cm ³ /rev)	16	23	33	41	48	60	76	100	140
转速 Speed (rpm)	1800	1800	1800	1800	1800	1800	1800	1800	1800
流量 Flow (L/min)	28.8	41.4	59.4	73.8	86.4	108	136.8	180	252
公称压力 Nominal pressure (bar)	248								
峰值压力 Max. pressure (bar)	310								
重量(近似值) Weight (approx.) (kg)	13.2	20.4	20.4	25	25	41	41	82	82
应用领域 Application field	机床锻压、冶金、工程、矿山、船舶等机械领域 Machine tool forging, metallurgy, engineering, mining, shipbuilding and other mechanical fields								

ATUS-PVM 系列

轴向柱塞变量泵

Axial Piston Variable Pump

产品参数及特点 Product Parameters

规格 Size NG	18	20	45	50	57	63	74	81	98	106	131	141
排量 Displacement (cm ³ /rev)	18	21.1	45.1	50	57.4	63.1	73.7	81	98.3	107	131	141
转速 Speed (rpm)	2800	2800	2600	2600	2500	2500	2400	2400	2200	2200	2000	2000
流量 Flow (L/min)	42	52	115	125	140	159	174	185	217	234	253	258
额定压力 Nominal pressure (bar)	280	230	280	230	280	230	280	230	280	230	280	230
峰值压力 Max. pressure (bar)	320	250	320	250	320	250	320	250	320	250	320	250
重量(近似值) Weight (approx.) (kg)	15	15	24	24	36	36	45	45	55	55	66	66
应用领域 Application field	应用于大型注塑机、冶金、港口等行业 Used in large injection molding machines, metallurgy, ports and other industries											



扫一扫查看电子说明书
Electronic instruction manual

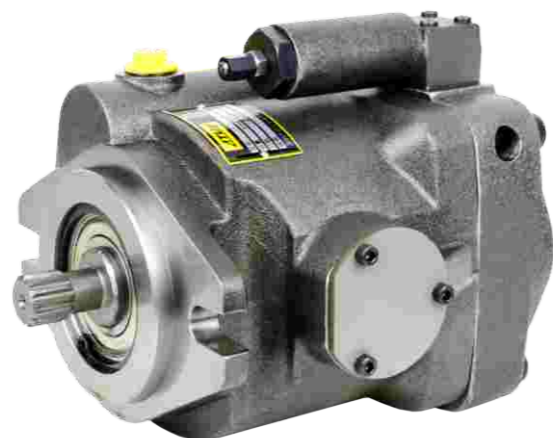

扫一扫查看电子说明书
Electronic instruction manual

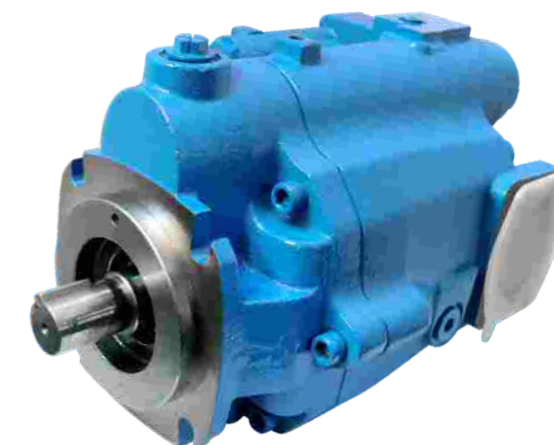



ATUS-A2F 系列

定量柱塞泵/马达

Fixed Displacement Pump/Motor

产品参数及特点

Product Parameters

规格 Size NG	10	12	23	28	45	55	63	80	107	125	160	200	250	355	500
排量 Displacement (cm ³ /rev)	9.6	12	23	28	44	55	63	80	107	125	160	200	250	355	500
转速 Speed (rpm)	7500	6000	5600	4750	4500	3750	4000	3350	3000	3150	3650	2500	2500	2240	2000
公称压力 Nominal pressure (bar)	350														
峰值压力 Max. pressure (bar)	400														
扭矩 Torque p=350bar (Nm)	52	65	126	156	247	305	351	445	595	696	890	1113	1391	1976	2783
重量(近似值) Mass(approx.) (kg)	5	5	12	12	23	23	33	33	44	63	63	63	88	138	185
应用领域 Application field	<p>工程设备中常用于起重机的回转液压系统，卷扬液压系统，在工业设备中用于高速搅拌，传送带驱动，风机等</p> <p>It is often used in the slewing hydraulic system of cranes and winch hydraulic systems in engineering equipment. It is used in high-speed mixing, conveyor belt drives, fans, etc. in industrial</p>														

ATUS-A2FO 系列

轴向柱塞定量泵

Axial Piston Fixed Pump

产品参数及特点

Product Parameters

规格 Size NG	5	10	12	16	23	28	32	45	56	63	80	90	107	125	160	180	200	250	355
排量 Displacement (cm ³ /rev)	4.93	10.3	12	16	22.9	28.1	32	45.6	56.1	63	80.4	90	107	125	160	180	200	250	355
转速 Speed (rpm)	5600	3150	3150	3150	2500	2500	2500	2240	2000	2000	1800	1800	1600	1600	1450	1450	1550	1500	1320
公称压力 Nominal pressure (bar)	315	400																	350
峰值压力 Max. pressure (bar)	350	450																	400
流量 Flow (L/min)	27.6	32	38	50	57	70	80	102	112	126	145	162	171	200	233	261	310	375	469
重量(近似值) Mass(approx.) (kg)	2.5	6	6	6	9.5	9.5	9.5	14	18	18	23	23	32	32	45	45	66	73	110
应用领域 Application field	<p>应用于工业及工厂自动化、行走机械、以及可再生能源等领域，如：钢铁行业、船舶和海洋钻井平台。</p> <p>Used in industrial and factory automation, mobile machinery, and renewable energy, such as the steel industry, ships and offshore drilling platforms.</p>																		



扫一扫查看电子说明书
Electronic instruction manual



扫一扫查看电子说明书
Electronic instruction manual

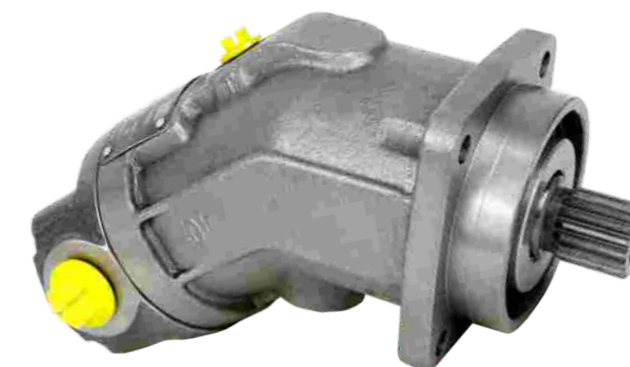



ATUS-A22VG 系列

轴向柱塞变量泵

Axial Piston Variable Pump

产品参数及特点 Product Parameters

规格 Size NG	45
排量 Displacement (cm ³ /rev)	46
转速 Speed (rpm)	3800
公称压力 Nominal pressure (bar)	350
峰值压力 Max. pressure (bar)	420
扭矩 Torque p=400bar (Nm)	512
重量(近似值) Mass(approx.) (kg)	55

应用领域 Application field

双缸柱塞变量泵，结构紧凑，用于闭式液压系统中，应用于小型的工程机械、农业机械、伐木机械中。
The double-cylinder plunger variable pump has a compact structure and is used in closed hydraulic systems and in small construction machinery, agricultural machinery, and logging machinery.



扫一扫查看电子说明书
Electronic instruction manual



ATUS-A4VSO 系列

轴向柱塞变量泵

Axial Piston Variable Pump

产品参数及特点 Product Parameters

规格 Size NG	40	71	125	180	250	355	500	750	1000
排量 Displacement (cm ³ /rev)	40	71	125	180	250	355	500	750	1000
转速 Speed (rpm)	2600	2200	1800	1800	1500	1500	1320	1200	1000
流量 Flow (L/min)	104	156	225	324	375	533	660	900	1000
公称压力 Nominal pressure (bar)	350								
峰值压力 Max. pressure (bar)	400								
重量(近似值) Weight(approx.) (kg)	39	53	88	102	184	207	320	460	605

应用领域 Application field

应用于开放式液压系统，主要用于钢铁行业、造纸行业、工程机械等
Used in open hydraulic systems, mainly used in the steel industry, paper industry, construction machinery, etc.



扫一扫查看电子说明书
Electronic instruction manual





ATUS-LR/KR 系列

轴向柱塞变量泵
Axial Piston Variable Pump

产品参数及特点 Product Parameters

规格 Size NG	L25C	L30D	K38C	K45D
排量 Displacement (cm ³ /rev)	25	30	38	45
转速 Speed (rpm)	3200	3200	2650	2650
公称压力 Nominal pressure (bar)	260	210	260	210
峰值压力 Max. pressure (bar)	350	300	350	300
流量 Flow (L/min)	80	96	100.7	119.3
重量 (近似值) Mass (approx.) (kg)	19			
应用领域 Application field	应用于起重搬运机械、林业与农业机械机械、采矿设备、小型工程机械及其他液压系统中。 Used in lifting and handling machinery, forestry and agricultural machinery, mining equipment, small construction machinery and other hydraulic systems.			



扫一扫查看电子说明书
Electronic instruction manual



ATUS-ER 系列

轴向柱塞变量泵
Axial Piston Variable Pump

产品参数及特点 Product Parameters

规格 Size NG	E100B	E130B	E147C
排量 Displacement (cm ³ /rev)	90	130	147
转速 Speed (rpm)	2450	2200	2100
公称压力 Nominal pressure (bar)	310	310	260
峰值压力 Max. pressure (bar)	400	400	350
流量 Flow (L/min)	245	286	308.7
重量 (近似值) Mass (approx.) (kg)	51.3		
应用领域 Application field	应用于铺路机械，如：压路机，沥青摊铺机，自卸车 Applied to paving machinery, such as: road rollers, asphalt pavers, dump trucks, etc.		



扫一扫查看电子说明书
Electronic instruction manual





ATUS-JR 系列

轴向柱塞变量泵

Axial Piston Variable Pump

产品参数及特点

Product Parameters

规格 Size NG	J45B	J51B	J60B	J65C	J75C
排量 Displacement (cm ³ /rev)	45	51	60	65	75
转速 Speed (rpm)	2900	2700	2600	2500	2400
公称压力 Nominal pressure (bar)	310			260	
峰值压力 Max. pressure (bar)	400			350	
流量 Flow (L/min)	126	137.7	156	162.6	180
重量(近似值) Mass (approx.) (kg)	23.1				
应用领域 Application field	应用于农业机械, 环卫车等, 如: 收割机, 刈草机, 拖拉机, 扫地机... Used in agricultural machinery, sanitation vehicles, etc., such as: harvesters, mowers, tractors, sweepers...				

ATUS-FR 系列

轴向柱塞变量泵

Axial Piston Variable Pump

产品参数及特点

Product Parameters

规格 Size NG	F74B	F90C
排量 Displacement (cm ³ /rev)	74	90
转速 Speed (rpm)	2400	2200
公称压力 Nominal pressure (bar)	310	260
峰值压力 Max. pressure (bar)	400	350
流量 Flow (L/min)	177.6	198
重量(近似值) Mass (approx.) (kg)	29.5	
应用领域 Application field	应用于铲运机械中, 如: 装载机, 推土机, 平地机。 Used in scraper machinery, such as: loaders, bulldozers, graders.	



扫一扫查看电子说明书
Electronic instruction manual



扫一扫查看电子说明书
Electronic instruction manual





ATUS-90 系列

轴向柱塞变量泵

Axial Piston Variable Pump

产品参数及特点

Product Parameters

规格 Size NG	42	55	75	100	130	180	250
排量 Displacement (cm ³ /rev)	42	50	75	100	130	180	250
转速 Speed (rpm)	4200	3900	3600	3300	3100	2600	2300
流量 Flow (L/min)	176	215	270	330	403	468	575
公称压力 Nominal pressure (bar)	420						
峰值压力 Max. pressure (bar)	480						
重量 (近似值) Mass (approx.) (kg)	34	40	49	68	88	136	154
应用领域 Application field	应用于农用机械及工程机械的闭式液压系统中，如：旋耕机，玉米收割机，搅拌机，混凝土泵车等 Used in closed hydraulic systems of agricultural machinery and construction machinery, such as: rotary tillers, corn harvesters, mixer trucks, concrete pump trucks, etc.						

ATUS-A7VO 系列

轴向柱塞变量泵

Axial Piston Variable Pump

产品参数及特点

Product Parameters

规格 Size NG	28	55	80	107	160	250	355	500
排量 Displacement (cm ³ /rev)	28.1	54.8	80	107	160	250	255	500
转速 Speed (rpm)	3150	2500	2240	2150	1900	1500	1320	1200
公称压力 Nominal pressure (bar)	350							
峰值压力 Max. pressure (bar)	400							
流量 Flow (L/min)	89	137	179	230	304	364	455	582
重量 (近似值) Mass (approx.) (kg)	17	25	40	49	71	102	173	234
应用领域 Application field	应用于各种液压系统和工程设备中，以提供液压能力和控制。它适用于各种工业应用和设备，包括但不限于以下领域：建筑工程、农业机械、工业机械、挖掘和采矿、海洋工程。 Used in various hydraulic systems and engineering equipment to provide hydraulic capability and control. It is suitable for a variety of industrial applications and equipment, including but not limited to the following areas: construction engineering, agricultural machinery, industrial machinery, excavation and mining, marine engineering.							



扫一扫查看电子说明书
Electronic instruction manual

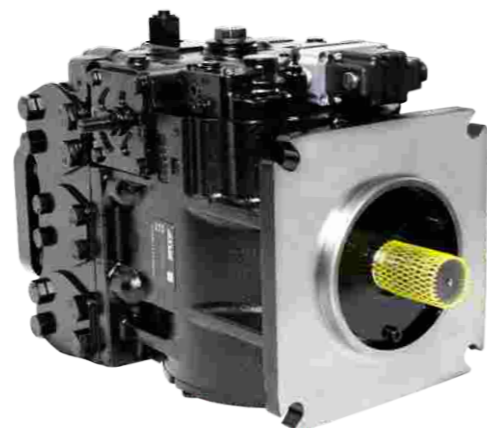

扫一扫查看电子说明书
Electronic instruction manual

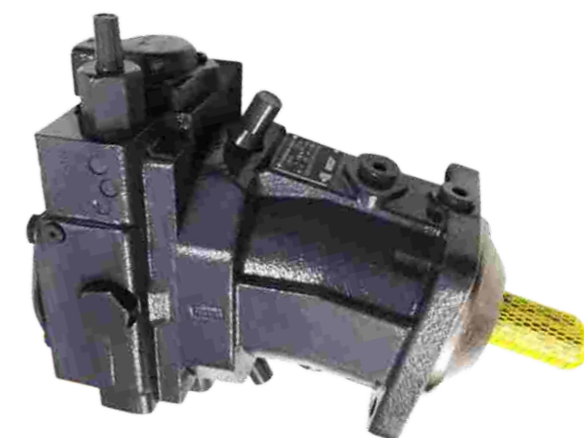



ATUS-A2FM 系列

轴向柱塞定量马达
Axial Piston Fixed Motor

产品参数及特点 Product Parameters

规格 Size NG	10	12	16	23	28	32	45	56	63	80	90	107	125	160	180	200	250	355
排量 Displacement (cm ³ /rev)	10	12	16	23	28	32	45	56	63	80	90	107	125	160	180	200	250	355
转速 Speed (rpm)	8000	8000	8000	6300	6300	6300	5600	5000	5000	4500	4500	4000	4000	3600	3600	2750	2700	2240
公称压力 Nominal pressure (bar)	400																350	
峰值压力 Max. pressure (bar)	450																400	
扭矩 Torque p=350bar (Nm)	57	67	89	128	157	178	254	313	351	448	501	594	696	893	1003	1114	1393	1978
重量(近似值)Weight(approx.)(kg)	5.4	5.4	5.4	9.5	9.5	9.5	14	18	18	23	23	32	32	45	45	66	73	110
应用领域 Application field	应用于各种机械设备的旋转执行单元，如：回转、绞车、行走、旋转动力头 Rotary execution units used in various mechanical equipment, such as: rotary, winch, walking, rotating power heads																	



ATUS-A2FE 系列

柱塞定量插入式马达
Plunger Quantitative Insertion Motor

产品参数及特点 Product Parameters

规格 Size NG	28	32	45	56	63	80	90	107	125	160	180	250	355
排量 Displacement (cm ³ /rev)	28	32	45	56	63	80	90	107	125	160	180	250	355
转速 Speed (rpm)	6300	6300	5600	5000	5000	4500	4500	4000	4000	3600	3600	2700	2240
公称压力 Nominal pressure (bar)	400												350
峰值压力 Max. pressure (bar)	450												400
扭矩 Torque p=350bar (Nm)	157	178	254	313	351	448	501	594	696	893	1003	1393	1978
重量(近似值)Weight(approx.)(kg)	10.5	10.5	15	18	19	23	25	34	36	47	48	82	110
应用领域 Application field	应用于各类旋转机械设备中，如：回转、卷扬、行走等 Used in various rotating machinery and equipment, such as: rotation, winch, walking, etc.												



扫一扫查看电子说明书
Electronic instruction manual



扫一扫查看电子说明书
Electronic instruction manual





ATUS-A11V(L)O 系列

轴向柱塞变量泵
Axial Piston Variable Pump

产品参数及特点 Product Parameters

规格 Size NG	ATUS-A11VO								ATUS-A11VLO			
	40	60	75	95	130	145	190	260	130	145	190	260
排量 Displacement (cm ³ /rev)	42	58.5	74	93.5	130	145	193	260	130	145	193	260
转速 Speed (rpm)	3000	2700	2550	2350	2100	2200	2100	1800	2500	2500	2500	2300
流量 Flow (L/min)	126	158	189	220	273	319	405	468	325	363	483	598
公称压力 Nominal pressure (bar)	350											
峰值压力 Maxi. pressure (bar)	400											
重量(近似值) Weight (approx.) (kg)	32	40	45	53	66	76	95	125	72	73	104	138
应用领域 Application field	应用于矿山机械、工程机械、船舶等设备的液压系统中 Used in hydraulic systems of mining machinery, engineering machinery, ships and other equipment											



扫一扫查看电子说明书
Electronic instruction manual

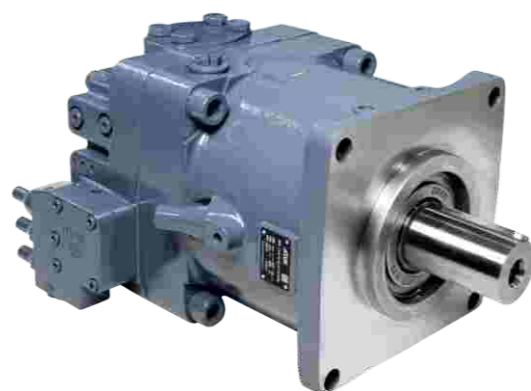

ATUS-A4VG 系列

轴向柱塞变量泵
Axial Piston Variable Pump

产品参数及特点 Product Parameters

规格 Size NG	28	40	56	71	90	125	180	250
排量 Displacement (cm ³ /rev)	28	40	56	71	90	125	180	250
转速 Speed (rpm)	4250	4000	3600	3300	3050	2850	2500	2400
流量 Flow (L/min)	119	160	201.6	234.3	274.5	356.25	450	600
公称压力 Nominal pressure (bar)	400							
峰值压力 Max. pressure (bar)	450							
重量(近似值) Weight (approx.) (kg)	29	31	38	50	60	80	101	156
应用领域 Application field	应用于工程机械、农业机械、矿山机械，用于闭式系统，为旋转部件提供液压能等 Used in engineering machinery, agricultural machinery, mining machinery, and used in closed systems to provide hydraulic energy for rotating parts, etc.							



扫一扫查看电子说明书
Electronic instruction manual

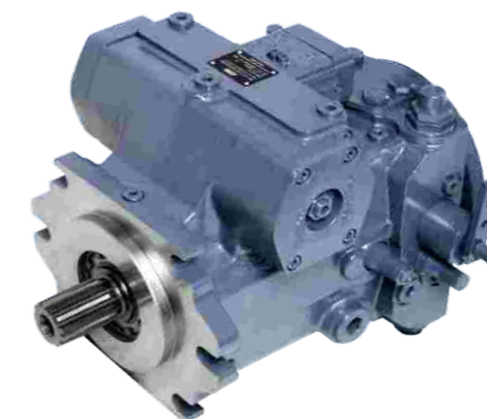



ATUS-P2/P3 系列

轴向柱塞变量泵
Axial Piston Variable Pump

产品参数及特点 Product Parameters

规格 Size NG	ATUS-P2				ATUS-P3	
	P2060	P2075	P2105	P2145	P3105	P3145
排量 Displacement (cm ³ /rev)	60	75	105	145	105	145
转速 Speed (rpm)	2800	2500	2300	2200	2600	2500
流量 Flow (L/min)	168	187.5	241.5	319	273	362.5
公称压力 Nominal pressure (bar)	320					
峰值压力 Max. pressure (bar)	370					
重量(近似值) Mass (approx.) (kg)	37	44	63	78	62	76
应用领域 Application field	应用于特种车辆上的液压系统，涉及油田设备，矿山设备，工业搬运设备。 Hydraulic systems used on special vehicles, involving oil field equipment, mining equipment, and industrial handling					

ATUS-PAVC 系列

轴向柱塞变量泵
Axial Piston Variable Pump

产品参数及特点 Product Parameters

规格 Size NG	33	38	65	100
排量 Displacement (cm ³ /rev)	33	38	65	100
转速 Speed (rpm)	1800	1800	1800	1800
流量 Flow (L/min)	59.4	68.4	117	180
公称压力 Nominal pressure (bar)	207			
峰值压力 Max. pressure (bar)	248			
重量(近似值) Weight (approx.) (kg)	18	18	28	50
应用领域 Application field	应用于注塑机、工程机械、冶金、塑料机械、造纸等工业领域行业 Used in injection molding machines, engineering machinery, metallurgy, plastic machinery, papermaking and other industrial fields			



扫一扫查看电子说明书
Electronic instruction manual

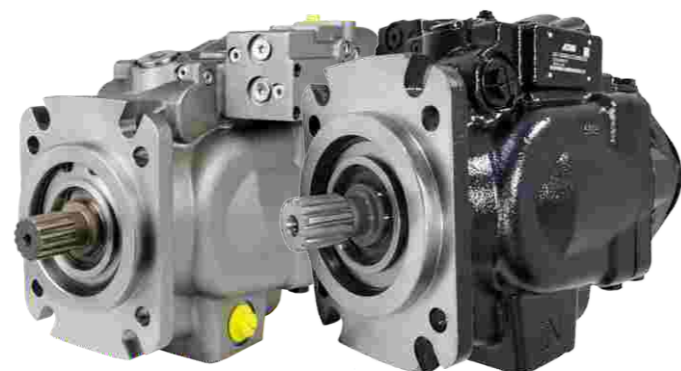

扫一扫查看电子说明书
Electronic instruction manual



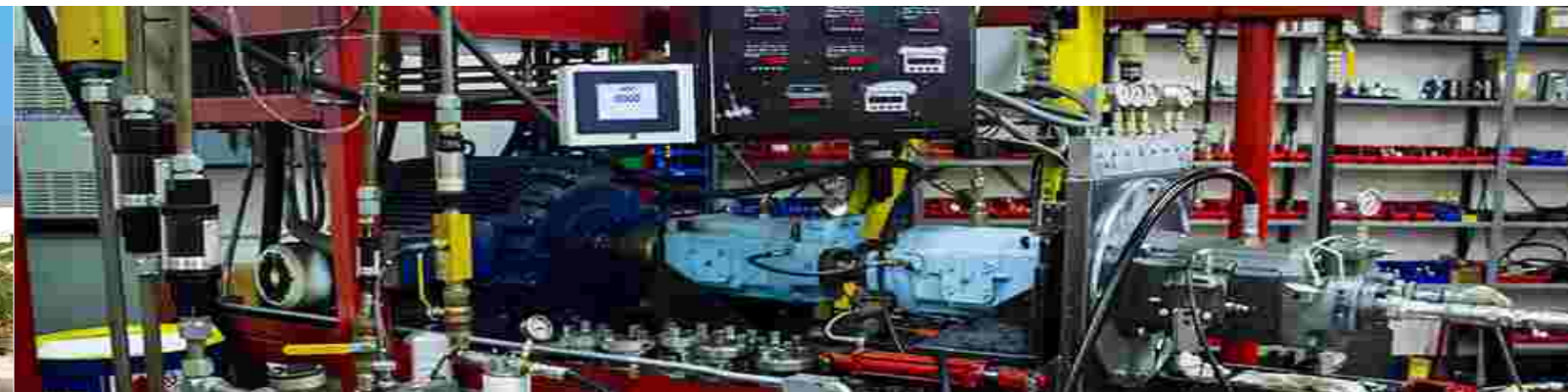

ATUS-ADU 系列

轴向柱塞变量泵

Axial Piston Variable Pump

产品参数及特点 Product Parameters

规格 Size NG	41	49	62
排量 Displacement (cm ³ /rev)	41.0	49.2	62.3
转速 Speed (rpm)	2650	2650	2600
公称压力 Nominal pressure (bar)	280		
峰值压力 Max. pressure (bar)	350		
流量 Flow (L/min)	104	126	156
重量(近似值) Mass (approx.) (kg)	21	21	22

应用领域 Application field

在小中型设备中常作主泵使用，如农用拖拉机，反铲装载机，开沟机等；在大型机械中做副泵或其他功能泵使用，如：矿山机械，伐木机，起重机等。

It is often used as the main pump in small and medium-sized equipment, such as agricultural tractors, backhoe loaders, trenchers, etc.; it is used as an auxiliary pump or other functional pump in large machinery, such as: mining machinery, logging machines, cranes, etc.



扫一扫查看电子说明书
Electronic instruction manual



ATUS-9A 阀

电液比例变量控制

Electro-hydraulic Proportional Variable Control

产品参数及特点 Product Parameters

响应时间 Response time	0.9S
	1.5S
	1.8S
要求的伺服控制压力 Required servo control pressure	14 - 70bar(200 - 1000psi) , 标称值为 28bar(400psi)
电磁线圈电阻 Solenoid resistance	41Ω(24V 线圈) & 10Ω(12V 线圈)
适用油液类型 Applicable fluid type	所有类型油液 (All types of fluids)
电气插头 Electrical plug	DIN 43650 AF 型 , 16-01008 -8



扫一扫查看电子说明书
Electronic instruction manual





ATUS-300 系列减速机

行星驱动
Planetary Drive

产品参数及特点 Product Parameters

规格 Size NG	309	310	311
传动比 Gear ratio (i)	3.4 ~ 2400	4 ~ 2500	4 ~ 2100
输出扭矩 Output torque (Nm)	1000 ~ 18000	1000 ~ 25000	1000 ~ 40000
应用领域 Application field	与高速液压马达组合，用于需要大扭矩低转速的设备中，如：旋挖钻机动力头，回转台，破碎站等 Combined with high-speed hydraulic motors, used in equipment that requires high torque and low speed, such as rotary drilling power heads, rotary tables, crushing stations, etc		

ATUS-ED 系列减速机

行星驱动
Planetary Drive

产品参数及特点 Product Parameters

规格 Size NG	2250
传动比 Gear ratio (i)	14.14 ~ 36
输出扭矩 Output torque (Nm)	9056 ~ 35000
应用领域 Application field	与高速液压马达组合，用于需要大扭矩低转速的设备中，如：旋挖钻机动力头，回转台，破碎站等 Combined with high-speed hydraulic motors, used in equipment that requires high torque and low speed, such as rotary drilling power heads, rotary tables, crushing stations, etc



扫一扫查看电子说明书
Electronic instruction manual



扫一扫查看电子说明书
Electronic instruction manual

